

# Expansion of Power System Corridors Using Tier-1 Technique for Reactive Power Compensation

Samuel O. Ezennaya, Ezechukwu, O.A., Anierobi C.C., Akpe V.A

**Abstract**— This paper develops a novel strategy for the expansion of the power system corridors for the release of the embedded transmission capacity. Both theoretical and practical network models are presented with a focus on power flow studies which concentrates on the steady state or static behavior of electrical power system. The methodology involves the power flow analysis revalidation of the existing standard IEEE 14 bus system and simulation using Newton-Raphson method in both MATLAB and Powerworld simulator (PWS) environment. This paper therefore establishes that an original designed network could be modified to take more loads without building new generators or transmission lines. The expansion of the existing IEEE 14 bus network to accommodate more load involves the use of static compensators incorporated at the transmission lines. This technique is then analyzed extensively when distributed along the lines through the use of a distributed capacitors compensators, (DCC). DCC can affect significant change in power line impedance to improve the power transfer capacity of an interconnected power system. The application of the DCC on the line is the tier-1 technique. The results obtained show that by applying the tier-1 techniques to the transmission line, the system's capacity will remarkably improve and the transmission line will accept extra loading.

**Index Terms**— Power corridors, Newton-Raphson, Static compensators, DCC, Tier-1 compensation, PWS, MATLAB

## 1 INTRODUCTION

Electrical energy efficiency is of prime importance to industrial and commercial companies operating in today's competitive markets. Optimum use of power system components is one main concern that needs to be balanced with energy efficiency, for both economic and environmental reasons. Electricity plays a fundamental role in the economic development of any country. Every country seeks to ensure supply of electricity that is affordable, reliable and secure in order to sustain modern ways of living. The availability of electricity greatly facilitates industrialization. This is because, electricity is a convenient way to transport energy in which they are also converted into transmission, distribution, and consumption [1]. Investigations are done in this paper to see how capacitors distributed along the transmission lines can expand the transmission line corridor by the release of embedded trans-

mission capacity.

During the past two decades, the increase in electrical energy demand has presented higher requirements from the power industry. In interconnected power systems, it has become important to fully utilize the existing transmission facilities in preference to building new power plants and transmission lines that are costly to implement and involving long construction times. This necessitated the need for alternative technology through the use of solid state electronic devices with fast response characteristics [2]. The requirement was fuelled by worldwide restructuring of electric utilities, increased environmental and efficiency regulations and difficulty in getting permit and right of ways for the construction of overhead power transmission lines. Different approaches such as reactive power compensation and phase shifting have been applied to increase the capacity, stability and security of the power system. This need in conjunction with the development of semiconductor thyristor switch opened the door for the development of flexible alternating current transmission system (FACTS) controllers [3]. FACTS controllers make it possible to

- Samuel O. Ezennaya is currently pursuing Pd.D program in electrical engineering in Nnamdi Azikiwe University, Awka Nigeria, PMB 5025, Awka\*\*\*mail no. E-mail: [ezennayasamuel@gmail.com](mailto:ezennayasamuel@gmail.com)
- Ezechukwu O.A is currently an associate professor in electric power engineering in Nnamdi Azikiwe University, Awka Nigeria, PMB 5025, Awka\*\*\*. E-mail: [oselokaechukwu@gmail.com](mailto:oselokaechukwu@gmail.com)
- Anierobi C.C. is currently pursuing Pd.D program in electrical engineering in Nnamdi Azikiwe University, Awka Nigeria, PMB 5025, Awka\*\*\*mail no. E-mail: [cc.anierobi@unizik.edu.ng](mailto:cc.anierobi@unizik.edu.ng)
- Akpe V.A is currently pursuing Pd.D program in electrical engineering in Nnamdi Azikiwe University, Awka Nigeria, PMB 5025, Awka\*\*\*mail no.

control the voltage magnitude of a bus, active and reactive power flows through transmission line of a system.

### 1.1: POWER SYSTEMS CONTROL

Reactive power control service should satisfy the following system requirements [4];

- Satisfy overall system and customer requirements for reactive energy on a continuous basis;
- Maintaining system voltages within acceptable limits;
- Provide a reserve to cover the changed reactive requirements caused by contingencies, against which the system is normally secured, and satisfy certain quality criteria in relation to speed of response;
- Optimize system losses.

Three tiers could be established in reactive power control. These are tier-1, tier-2, and tier-3 controls. However, two or more of the three tiers can simultaneously be applied to form a hybrid tier control. A description of the three tiers of reactive power control could be made;

- Tier-1 control** co-ordinates the action of voltage and reactive power control devices within the transmission zones of the network in order to maintain the requisite voltage level at a certain node points in the system.
- Tier-2 control** involves a process of load optimization by improving load power factors which influence the distribution of reactive power, where the system load is high, and the operator must be certain that, in case of a loss of generation, the remaining facilities will be able to deliver enough reactive power to keep the voltage within the required range. The same applies to the converse situation, where the system load is low and reactive power needs to be absorbed.
- Tier-3 control** is the generator control.

- Hybrid-Tier control** is the simultaneous application of both the tier-1, and tier-2 or tier-3. It can also involve the control at the three tier controls to the power system at the same time.

### 1.2: SOURCES OF REACTIVE POWER

Reactive power is produced or absorbed by all major components of a power system [4];

- Generators;
- Power transfer components;
- Loads;
- Reactive power compensation devices.

### 2.0: POWER SYSTEMS REACTIVE POWER COMPENSATION

Reactive power compensation otherwise called reactive var compensation is the management of reactive power to improve the performance of AC power systems, maximizing stability by increasing flow of active power. Compensation can be carried out in series or in parallel (shunt). Series and shunt var compensation are used to modify the natural electrical characteristic of AC transmission or distribution system parameters as well as changes the equivalent impedance of the load.

#### Devices for reactive power compensation

- synchronous condensers
- Flexible alternating current transmission system (FACTS) controllers.
- the distributed capacitor compensation (DCC)

### 2.1: THE DISTRIBUTED CAPACITOR COMPENSATION (DCC) BASIS

There are many different methods used for compensation in power systems. Some of these methods include reducing generator and transformer reactance, increasing the number of parallel lines used, using shunt capacitor compensators, or using series capacitor compensators [5].

DCC can be used in series or in parallel on a transmission line. The addition of DCC in series serves multiple purposes, the most important being the improvement in stability along the entire line. Its addition in parallel (shunt compensation) is used to support voltage at certain point on the line as opposed to the entire line and also inject or absorb reactive power to the loads. Series and Shunt compensation have been in use since the early part of the 20<sup>th</sup> century. The first application of shunt compensation was in 1914 and has been used ever since becoming the most common method of capacitive compensation. Series compensation was first used in the United States for NY Power & Light in 1928, but didn't become popular until the 1950's when the voltage levels that could be handled began increasing. By 1968, a 550kV application had been implemented and today there are applications approaching 800kV [6].

The principal applications of DCC are;

- Improves voltage regulation
- Expand power transmission corridor of the transmission line
- Improves system stability

The applications previously mentioned are merely a selected few of the uses that DCC devices can provide. These applications and others are used throughout the world to improve the system as a whole. One common location where DCC devices are used heavily is on long transmission lines fed from hydroelectric generating plants. Many of the lines use the DCC devices to improve voltage regulation because the main load area is commonly several hundred kilometers from the generating station, allowing for large voltage decay.

## 2.2: DCC CIRCUIT

Capacitor compensator circuit is made up of the capacitor module and its protective scheme. The protective scheme shown in fig 1 consists of [7];

- A metal oxide varistor (MOV);
- Current limiting damping equipment (CLDE);

- Fast protective Device (FPD); and
- By-pass switch (B).

The MOV has been designed to withstand the energy from external faults; faults appearing outside the series compensated circuit, without by-passing the DCC. The DCC module may be by-passed for any internal fault, (faults in the same circuit where the DCC is located). Each DCC is connected and disconnected from the line by means of two isolating disconnectors and one by-pass disconnector. The by-pass switch is of Sf<sub>6</sub> type, with a spring operating mechanism.

The CLDE consists of a current limiting reactor, a resistor and a varistor in parallel with the reactor. The purpose of the resistor is to add damping to the capacitor discharge current, and thus quickly reduce the voltage across the capacitor after a by-pass operation. The varistor help to avoid fundamental frequency losses in the damping resistor during steady state operation.

The FPD scheme is based on a hermetically sealed and very fast high power switch, which replaces conventional spark gaps. The FPD works in combination with the MOV, and allows by-passing in a very controlled way in order to reduce the energy dissipated in the MOV.

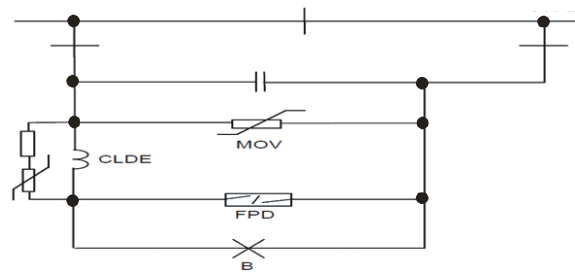

**Figure 1.0:** The single line diagram of a one-capacitor compensator in series [7]

## 3.0: THE MATHEMATICAL MODEL OF TIER-1 COMPENSATION

Electrical power is transmitted through the transmission line from the sending-end of the line to the receiving-end of the

line. This can be analyzed through parameterization and modeling of the transmission line with passive components such as resistors, capacitors and inductors. The quantities of these parameters depend mostly on the line conductors and the physical or geometrical configuration of the lines. These conductors will have certain characteristics such as resistance and reactance both in series (from sending to receiving-ends of the line) and shunts (from the line to ground) associated with them.

### 3.1: BASIC PRINCIPLE OF POWER IN TRANSMISSION

Loads are more often expressed in terms of real (watts/KW) and reactive (vars/Kvars) power. It is convenient to deal with transmission line equations for the sending and receiving-end complex power and voltages [8] [9].

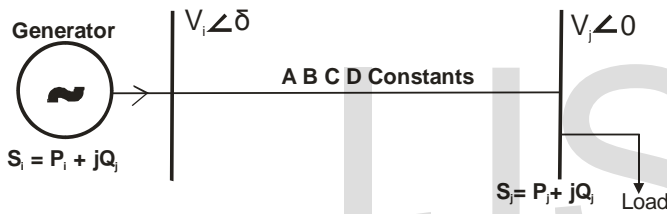

Figure 2.0: A two bus system

For a two-bus system shown in figure 2.0, the sending and receiving-end voltages are represented by the bus voltages while the sending end voltage leads the receiving end voltage by an angle,  $\delta$ . This angle is called the torque angle. The complex power leaving the receiving end and entering the sending-end of the transmission line can be expressed as

$$S_j = P_j + jQ_j = V_j I_j^* \quad \text{and} \quad S_i = P_i + jQ_i = V_i I_i^* \quad (1)$$

Where

$$P_j = \frac{|V_j||V_i|}{|Z|} \cos(\beta - \delta) - \frac{|V_j|^2}{|Z|} \cos(\beta) \quad \text{And}$$

$$Q_j = \frac{|V_j||V_i|}{|Z|} \sin(\beta - \delta) - \frac{|V_j|^2}{|Z|} \sin(\beta) \quad (2)$$

Similarly,

$$P_i = \left| \frac{1}{Z} \right| |V_i|^2 \cos(\beta) - \left| \frac{V_i||V_j|}{|Z|} \right| \cos(\beta + \delta) \quad (3)$$

$$Q_i = \left| \frac{1}{Z} \right| |V_i|^2 \sin(\beta) - \left| \frac{V_i||V_j|}{|Z|} \right| \sin(\beta + \delta) \quad (4)$$

At  $\delta = \beta$ , the maximum power delivered at the load will be;

$$P_j = \frac{|V_j||V_i|}{|Z|} - \frac{|V_j|^2}{|Z|} \cos(\beta); \quad (5) \quad \text{If, } \beta = \theta, \text{ then } \cos\theta = \frac{R}{|Z|}$$

(6)

But the resistance  $R$  of a transmission line is very small compared to its reactance, so that;

$$\theta = \tan^{-1} \left( \frac{X}{R} \right) \approx 90^\circ \quad (7); \quad \text{Where } Z = R + jX \text{ and } \theta = \delta.$$

Therefore the receiving-end power ( $P_j$ ) becomes;

$$P_j = \frac{|V_j||V_i|}{|X|} \sin(\delta) \quad \text{and} \quad Q_j = \frac{|V_j||V_i|}{|X|} \cos(\delta) - \frac{|V_j|^2}{|X|} \quad (8);$$

Hence  $Z \approx jX$ .

For a very small value of  $\delta$ ,  $\cos\delta = 1$ , thus;

$$Q_j = \frac{|V_j|}{|X|} (|V_i| - |V_j|); \quad (9) \quad \text{where } (|V_i| - |V_j|) = |\Delta V| \quad (10)$$

$|\Delta V|$  is called the magnitude of voltage drop across the transmission line.

Therefore;

$$Q_j = \frac{|V_j|}{|X|} |\Delta V| \quad (11)$$

### 3.2: REACTIVE POWER COMPENSATION OF TRANSMISSION LINES

Equations (8) through (11) indicate that the active and reactive power/current flow can be regulated by controlling the voltages, phase angles and line impedances of the transmission system. It has been shown above that the active power flow will reach the maximum when angle  $\delta$  is  $90^\circ$ .

#### 3.2.1: SERIES COMPENSATION OF A TRANSMISSION LINE

A series-connected capacitor adds a voltage in opposition to the transmission line voltage drop, therefore reducing the series line impedance.

Figure 3 show a simplified model of a transmission system with series compensation. The voltage magnitude of the sending-end is assumed equal as  $|V|$ , and the phase angle between them is  $\delta$ . The transmission line is assumed lossless and represented by the reactance  $X_L$ . A control capacitor is series-connected in the transmission line with voltage addition  $V_{inj}$ .

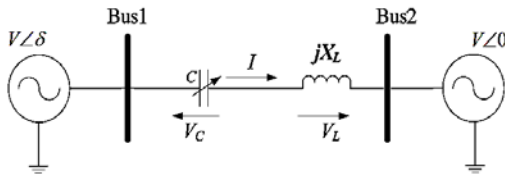

**Figure 3:** A simplified model of transmission system with series compensation [7].

**3.2.2: THE DEGREE OF SERIES COMPENSATION (Ks)**

The degree of series compensation or percentage compensation (*K<sub>s</sub>*) is used to analyze a transmission line with the required addition of series capacitor. It is defined as the fraction of *X<sub>c</sub>*, which refers to the total capacitive reactance of series compensators and *X<sub>L</sub>*, which refers to the total inductive reactance of the line, as defined in equation 12;

$$K_s = \frac{X_c}{X_L} \quad (12)$$

Therefore, the capacitance, *C* as a portion of the line reactance can be obtained from

$$X_c = K_s X_L \quad (13) \text{ and } C = \frac{1}{2\pi f X_c} \quad (14)$$

The overall series reactance, *X* of the transmission line is;

$$X = X_L - X_c = (1 - K_s) X_L \quad (15)$$

Thus the active power transmitted becomes;

$$P_i = P_j = \frac{|V|^2}{(1 - K_s) X_L} \sin \delta \quad (16)$$

The reactive power supplied by the capacitor is calculated as;

$$Q_c = 2 \frac{|V|^2 K_s}{X_L (1 - K_s)^2} (1 - \cos \delta) \quad (17)$$

From the above equation, it can be seen that transmitted active power increases with *K<sub>s</sub>* [10].

**3.3: EFFECTIVE LINE REACTANCE WITH AND WITHOUT DCC DEVICE**

Figure 4 shows a simple transmission line without a compensating device. Equation (18) is the effective line reactance in matrix form.

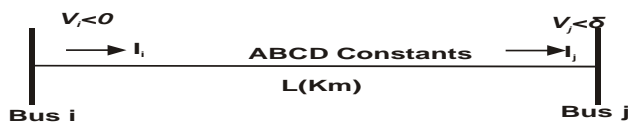

**Figure 4:** A simple transmission line without compensation

$$X_{eff} = \begin{bmatrix} A & B \\ C & D \end{bmatrix} \quad (3.17)$$

Where *X<sub>eff</sub>* is the effective reactance of the line.

The power flow equation becomes

$$\begin{bmatrix} V_i \\ I_i \end{bmatrix} = \begin{bmatrix} A & B \\ C & D \end{bmatrix} \begin{bmatrix} V_j \\ I_j \end{bmatrix} \quad (3.18)$$

Inserting a single series capacitor device on the line as in figure 4 changes the ABCD parameters and the effective reactance of the line becomes;

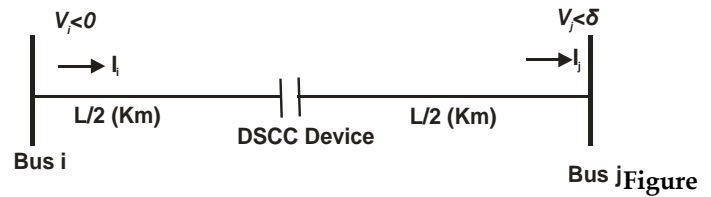

**Figure 5:** A transmission line with single DCC device (compensated line)

$$X_{eff} = \begin{bmatrix} A_{1/2} & B_{1/2} \\ C_{1/2} & D_{1/2} \end{bmatrix} * \begin{bmatrix} 1 & X_c \\ 0 & 1 \end{bmatrix} * \begin{bmatrix} A_{1/2} & B_{1/2} \\ C_{1/2} & D_{1/2} \end{bmatrix} \quad (20)$$

As the power flow equation changes to;

$$\begin{bmatrix} V_i \\ I_i \end{bmatrix} = \begin{bmatrix} A_{1/2} & B_{1/2} \\ C_{1/2} & D_{1/2} \end{bmatrix} * \begin{bmatrix} 1 & X_c \\ 0 & 1 \end{bmatrix} * \begin{bmatrix} A_{1/2} & B_{1/2} \\ C_{1/2} & D_{1/2} \end{bmatrix} \begin{bmatrix} V_j \\ I_j \end{bmatrix} \quad (21)$$

The ABCD parameters are halved because the DCC is placed at exactly midpoint (figure 6) to the length of the line hence one DCC device is used.

Inserting several series capacitor devices on the line will change the ABCD parameters hence the more the capacitors on the line are distributed, the better the performance. Figure 6 shows a transmission line with multiple series capacitor devices and equation 21 changes to;

$$X_{eff} = \begin{bmatrix} A_{1/4} & B_{1/4} \\ C_{1/4} & D_{1/4} \end{bmatrix} * \begin{bmatrix} 1 & X_c \\ 0 & 1 \end{bmatrix} * \begin{bmatrix} A_{1/4} & B_{1/4} \\ C_{1/4} & D_{1/4} \end{bmatrix} * \begin{bmatrix} 1 & X_c \\ 0 & 1 \end{bmatrix} * \begin{bmatrix} A_{1/4} & B_{1/4} \\ C_{1/4} & D_{1/4} \end{bmatrix} * \begin{bmatrix} 1 & X_c \\ 0 & 1 \end{bmatrix} * \begin{bmatrix} A_{1/4} & B_{1/4} \\ C_{1/4} & D_{1/4} \end{bmatrix} \quad (22)$$

The ABCD constants are divided by four (figure 6) when the DCC is placed at quarter of the line hence three Capacitors are used and placed at every quarter of the line.

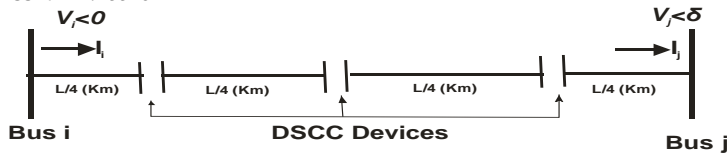

Figure 6: A transmission line with multiple DCC devices.

### 3.4: POWER FLOW INCLUDING DCC IN MATRIX FORMS

From equation (21), the transfer admittance matrix of the DCC is given by [11];

$$\begin{bmatrix} I_i \\ I_j \end{bmatrix} = \begin{bmatrix} jB_{ii} & jB_{ij} \\ jB_{ji} & jB_{jj} \end{bmatrix} * \begin{bmatrix} I_i \\ I_j \end{bmatrix} \quad (23)$$

Where

$$B_{ii} = B_{jj} = \frac{-1}{X_c}, \quad B_{ji} = B_{ij} = \frac{1}{X_c} \quad (24)$$

Equation (23) holds for inductive operation while for capacitive operation, the sign are reversed. The active and reactive power equations at bus  $j$  are as in equations (25) and (26) below;

$$P_j = V_j V_i B_{ij} \sin(\delta_j - \delta_i) \quad (25)$$

$$Q_i = -V_j^2 B_{jj} - V_j V_i B_{ij} \cos(\delta_j - \delta_i) \quad (26)$$

In Newton-Raphson solutions, these equations are linearized with respect to the series reactance. For the condition shown in figure 3 where series reactance regulates the amount of active power flowing from bus  $i$  to  $j$  at a value  $P$ , [11] the set of linearized power equation is,

$$\begin{bmatrix} \Delta P_i \\ \Delta P_j \\ \Delta Q_i \\ \Delta Q_j \\ \Delta P_{ij}^{X_c} \end{bmatrix} = \begin{bmatrix} \frac{\partial P_i}{\partial \delta_i} & \frac{\partial P_i}{\partial \delta_j} & \frac{\partial P_i V_i}{\partial V_i} & \frac{\partial P_i V_j}{\partial V_j} & \frac{\partial P_i X_c}{\partial X_c} \\ \frac{\partial P_j}{\partial \delta_i} & \frac{\partial P_j}{\partial \delta_j} & \frac{\partial P_j V_i}{\partial V_i} & \frac{\partial P_j V_j}{\partial V_j} & \frac{\partial P_j X_c}{\partial X_c} \\ \frac{\partial Q_i}{\partial \delta_i} & \frac{\partial Q_i}{\partial \delta_j} & \frac{\partial Q_i V_i}{\partial V_i} & \frac{\partial Q_i V_j}{\partial V_j} & \frac{\partial Q_i X_c}{\partial X_c} \\ \frac{\partial Q_j}{\partial \delta_i} & \frac{\partial Q_j}{\partial \delta_j} & \frac{\partial Q_j V_i}{\partial V_i} & \frac{\partial Q_j V_j}{\partial V_j} & \frac{\partial Q_j X_c}{\partial X_c} \\ \frac{\partial P_{ij}^{X_c}}{\partial \delta_i} & \frac{\partial P_{ij}^{X_c}}{\partial \delta_j} & \frac{\partial P_{ij}^{X_c}}{\partial V_i} & \frac{\partial P_{ij}^{X_c}}{\partial V_j} & \frac{\partial P_{ij}^{X_c}}{\partial X_c} \end{bmatrix} \begin{bmatrix} \Delta \delta_i \\ \Delta \delta_j \\ \Delta V_i \\ \Delta V_j \\ \Delta X_c \end{bmatrix} \quad (27)$$

$$\Delta P_{ij}^{X_c} = P_{ij}^{reg} - P_{ij}^{X_c cal} \quad (28)$$

Where,  $\Delta P_{ij}^{X_c}$  is the active power flow mismatch for the series reactance calculated;

$$\Delta X_c = X_c^{(n)} - X_c^{(n-1)} \quad (29)$$

$\Delta X_c$  is the incremental change in series reactance; and  $P_{ij}^{X_c cal}$

is the calculated power given by equation (25). The state variable  $X_c$  of the DCC controller is updated at the end of each iterative step according to equation (30);

$$X_c^{(n)} = X_c^{(n-1)} + \left( \frac{\Delta X_c}{X_c} \right)^{(n)} X_c^{(n-1)} \quad (30)$$

### 4.0: THE STANDARD IEEE 14 BUS TEST SYSTEMS (RE-VALIDATION)

One of the international load flow test systems is the IEEE-14 bus system. Load flow analysis is carried out in IEEE 14 bus test system. Figure 7 show the standard IEEE 14 bus network simulated in Powerworld platform. The run mode of Powerworld simulator enable the simulation of the existing IEEE 14 bus test system model using N-R iterative method to obtain the bus voltages, phase angles, line losses, real and reactive power flows. The system topology consists of 14 buses, 20 transmission lines or branches, 2 online generators, 3 online synchronous compensators used only for reactive power support, and 11 loads totaling 259MW and 78.7Mvar.

The simulated result of the test system in Powerworld shown in tables 1 gives a very close result when compared with the MATLAB results of tables 2. It was therefore confirmed that the result obtained when DCC is applied on the IEEE 14 bus network using only Powerworld simulation software due to its flexibility and simplicity.

Using codes written in MATLAB and system information exported from Powerworld simulator, the standard IEEE 14 bus network is revalidated and reconfirmed as follows;

### 5.0: SIMULATION RESULT

The revalidated Standard IEEE 14 bus network show that the total real and reactive power loss of the system are 15.31MW and 36.77Mvar respectively with the systems maximum current rating totaling 2948.91Amps. As a result, the system's maximum MVA loading becomes 696.604MVA. These results

confirmed and agreed with the standard performance of the standard IEEE 14 bus system as shown in tables 1A and B (Powerworld simulator tool) and table 2 A (MATLAB simulator tool). All bus voltages were also confirmed to fall within the recommended limit ( $0.9 \leq V \leq 1.1 \text{ p.u.}$ ).

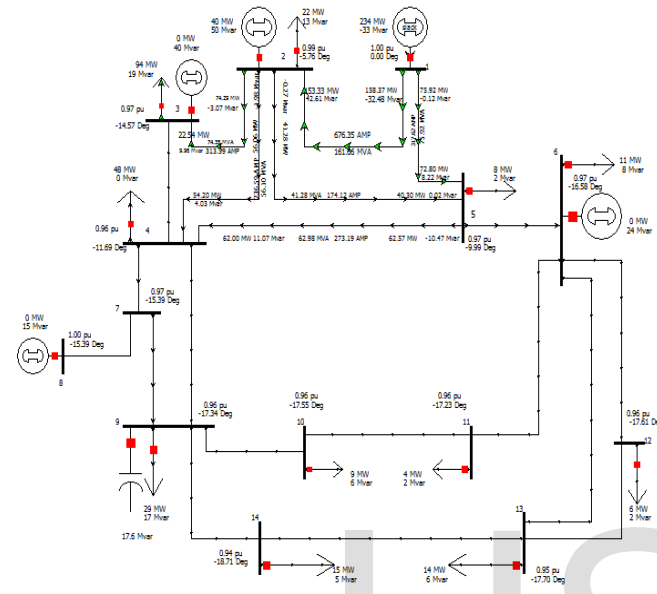

Figure 7: Standard IEEE 14 bus test system in Powerworld simulator environment.

Table 1A: Line records of the standard IEEE 14 bus system in Powerworld simulator.

Line Records																		
From NO	To NO	MW From	MW To	Max MW	Mvar From	Mvar To	Max Mvar	MVA From	MVA To	Max MVA	Amps From	Amps To	Max Amps	MW Loss	Mvar Loss			
1	2	158.4	153.333	158.366	-32.5	42.612	42.612	161.7	159.144	161.663	676.35	671.202	676.35	5.03	10.13			
1	5	75.9	-72.8	75.917	-0.1	8.218	8.218	75.9	73.263	75.917	317.615	316.494	317.615	3.12	8.1			
2	3	74.3	-71.654	74.289	-3.1	9.958	9.958	74.4	72.342	74.353	313.588	311.998	313.588	2.64	6.89			
2	4	56.1	-54.205	56.061	-2.0	4.028	4.028	56.1	54.354	56.096	236.587	235.762	236.587	1.86	2.05			
2	5	41.3	-40.295	41.283	-0.3	0.015	0.268	41.3	40.295	41.283	174.116	174.074	174.116	0.99	-0.25			
3	4	-22.5	23.019	23.019	11.0	-13.064	13.064	25.1	26.468	26.468	108.256	114.804	114.804	0.48	-2.02			
4	5	-62	62.574	62.574	11.1	-10.468	11.074	63	63.443	63.443	273.192	274.074	274.074	0.57	0.61			
4	7	29	-28.562	28.962	-3.1	5.033	5.033	29.1	29.396	29.396	126.351	126.351	126.351	0.00	1.91			
4	9	16.4	-16.431	16.431	1.1	0.534	1.087	16.5	16.439	16.466	71.424	71.424	71.424	0.00	1.62			
5	6	42.9	-42.922	42.922	0.6	4.317	4.317	42.9	43.139	43.139	185.444	185.444	185.444	0.00	4.95			
6	11	6.6	-6.584	6.636	2.8	-2.707	2.816	7.2	7.118	7.209	30.988	30.988	30.988	0.05	0.11			
6	12	7.7	-7.604	7.688	2.5	-2.278	2.454	8.1	7.938	8.07	34.693	34.693	34.693	0.08	0.18			
6	13	17.4	-17.156	17.401	6.9	-6.429	6.911	18.7	18.322	18.724	80.488	80.488	80.488	0.24	0.48			
7	8	0	-0.006	0.006	-14.7	15.132	15.132	14.7	15.132	15.132	63.308	63.308	63.308	0.00	0.4			
7	9	29	-28.956	28.956	9.7	-8.613	9.695	30.5	30.21	30.536	131.253	131.253	131.253	0.00	1.08			
9	10	5.9	-5.922	5.943	5.0	-4.911	4.966	7.7	7.694	7.745	33.649	33.649	33.649	0.02	0.05			
9	14	10	-9.793	9.953	4.1	-3.8	4.139	10.8	10.505	10.779	46.831	46.831	46.831	0.16	0.34			
10	11	-3.1	3.084	3.084	-0.9	0.907	0.907	3.2	3.215	3.215	13.996	13.996	13.996	0.01	0.02			
12	13	1.5	-1.498	1.504	0.7	-0.673	0.679	1.7	1.642	1.651	7.215	7.215	7.215	0.01	0.01			
13	14	5.2	-5.103	5.156	1.3	-1.197	1.305	5.3	5.241	5.319	23.366	23.366	23.366	0.05	0.11			
TOTAL		490	474.547	666.151	0.1	36.614	148.663	693.9	685.3	696.604	2948.71	2947.414	2956.14	15.31	36.77			

Total power loss in Powerworld simulator: 15.31 MW and 36.77 Mvar

Table 1B: Bus records of IEEE 14 bus system in Powerworld simulator.

Bus Records										
Number	Name	Nom kV	PU Volt	Volt (kV)	Angle (Deg)	Load MW	Load Mvar	Gen MW	Gen Mvar	S.Sht Mvar
1	1	138	1.00000	138.000	0.00			234.28	-32.6	
2	2	138	0.99197	136.892	-5.76	21.7	12.7	40	50	
3	3	138	0.97006	133.869	-14.57	94.2	19	0	40	
4	4	138	0.96454	133.107	-11.69	47.8	0			
5	5	138	0.96845	133.646	-9.99	7.6	1.6			
6	6	138	0.97323	134.306	-16.58	11.2	7.5	0	24	
7	7	138	0.97334	134.322	-15.39					
8	8	138	1.00000	138.000	-15.39			0	15.13	
9	9	138	0.96294	132.886	-17.34	29.5	16.6			17.62
10	10	138	0.95663	132.015	-17.55	9	5.8			
11	11	138	0.96106	132.626	-17.23	3.5	1.8			
12	12	138	0.95722	132.097	-17.61	6.1	1.6			
13	13	138	0.95233	131.422	-17.7	13.5	5.8			
14	14	138	0.93845	129.507	-18.71	14.9	5			

**Table 2A:** The bus records of the IEEE 14 bus system in MATLAB tool.

BUS NO	BUS VOLTAGE		LOAD		GENERATION		INJECTED MVAR
	MAGNITUDE	ANGLE	MW	MVAR	MW	MVAR	
1	1.050	0	0	0	234.029	61.651	0
2	1.000	-4.664	21.7	12.7	40	-11.307	0
3	0.970	-13.283	94.2	19	0	36.233	0
4	0.964	-10.372	47.8	0	0	0	0
5	0.970	-8.79	7.6	1.6	0	0	0
6	1.000	-15.109	11.2	7.5	0	14.105	0
7	0.979	-13.768	0	0	0	0	0
8	1.000	-13.768	0	0	0	12.064	0
9	0.963	-15.594	29.5	16.6	0	0	0
10	0.962	-15.835	9	5.8	0	0	0
11	0.977	-15.608	3.5	1.8	0	0	0
12	0.982	-16.085	6.1	1.6	0	0	0
13	0.976	-16.134	13.5	5.8	0	0	0
14	0.949	-17.014	14.9	5	0	0	0

The tables above confirmed that the standard IEEE 14 bus system total power loss in Powerworld simulator is 15.31 MW and 36.77 Mvar and that of MATLAB is 15.031MW and 35.348Mvar. This is a clear indication that the software tool used for this model is validated.

**5.1: CASE 1: MODIFICATION OF THE IEEE 14 BUS NETWORK (ADDITION OF AN EXCESS LOAD TO THE NETWORK)**

To illustrate that an already saturated network can be expanded by the use of capacitors distributed along the lines at strategic places, an existing load of a selected Company in Nigeria was used - the General Steel Mills (GSM), Asaba. The Company's total maximum active and reactive power demand are **17.80 MW** and **25.71 Mvar** respectively [12]. These loads were added to bus 6 of the standard IEEE 14 bus system which modified the revalidated results of the system. The active and reactive power losses increased from the normal operating performance of the 14 bus standard network to **59.85MW** and **226.84Mvar** respectively. The system's maximum amperage was **5658.287Amps** as all the bus voltages dropped below **0.9 p.u** except the slack bus-bus 1 (Table 3A). The MVA maximum loading also increased to **1062.225MVA (Overloading)**. For

these reasons, it is enough to say that the modified IEEE 14 bus system got overloaded and cannot accept this extra load.

**Table 3A:** Bus records of the modified standard IEEE 14 bus network (with **17.80 MW** and **25.71 Mvar** extra load addition)

Bus Records NO	Name	Nom kv	PU Volt	Volt (kv)	Angle (Deg)	Load MW	Load Mvar	Gen MW	Gen Mvar	S.Shmts Mvar
1	1	138	1	138	0			256.71	371.82	
2	2	138	0.82572	113.95	-4.21	21.7	12.7	40	50	
3	3	138	0.62455	86.188	-17.9	91.53	19.72	0	0	
4	4	138	0.59434	82.018	-10.26	45.16	113.38			
5	5	138	0.6584	90.859	-8.27	7.53	1.59			
6	6	138	0.48283	66.63	-24.44	13.9	20.07	0	0	
7	7	138	0.51624	71.241	-19.52					
8	8	138	0.51624	71.241	-19.52			0	0	
9	9	138	0.48187	66.497	-25.52	22.98	12.93			0
10	10	138	0.4696	64.804	-26.41	6.8	4.38			
11	11	138	0.47045	64.923	-25.93	2.65	1.36			
12	12	138	0.45884	63.32	-27.46	4.48	1.18			
13	13	138	0.45279	62.486	-27.67	9.75	4.19			
14	14	138	0.43901	60.583	-30.11	10.35	3.47			

**Table 3B:** Line records of the modified standard IEEE 14 bus network (with **17.80 MW** and **25.71 Mvar** extra load addition)

Line Records		From NO	To NO	MW From	MW To	Max MW	Mvar From	Mvar To	Max Mvar	MVA From	MVA To	Max MVA	Amps From	Amps To	Max Amps	MW Loss	Mvar Loss
1	2	180.8	163.425	180.84	236.4	187.704	236.434	297.7	248.879	297.665	1245.34	1260.995	1260.995	17.41	48.73		
1	5	75.9	-62.494	75.872	135.4	-83.694	135.39	155.2	104.452	155.2	649.309	663.723	663.723	13.38	51.7		
2	3	78.9	-70.943	78.86	71.1	-40.085	71.092	106.2	81.485	106.174	537.953	545.84	545.84	7.92	31.01		
2	4	59.1	-49.186	59.135	89.1	-60.896	89.147	107	78.279	106.978	542.024	551.028	551.028	9.95	28.25		
2	5	43.7	-38.501	43.728	64.8	-50.701	64.764	78.1	63.662	78.144	395.932	404.532	404.532	5.23	14.06		
3	4	-20.6	22.075	22.075	20.4	-17.848	20.36	29	28.388	28.953	193.949	199.83	199.83	1.49	2.51		
4	5	-55.2	58.335	58.335	-72.6	81.951	81.951	91.2	100.593	100.593	641.907	639.204	641.907	3.13	9.37		
4	7	23.6	-23.608	23.608	24.1	-17.367	24.107	33.7	29.308	33.741	237.514	237.514	237.514	0.00	6.74		
4	9	13.5	-13.546	13.546	13.8	-7.991	13.832	19.4	15.697	19.36	136.283	136.283	136.283	0.00	5.9		
5	6	35.1	-35.126	35.126	50.9	-28.647	50.857	61.8	45.326	61.808	392.751	392.751	392.751	0.00	22.21		
6	11	3.6	-3.543	3.603	1.3	-1.196	1.322	3.8	3.74	3.838	33.258	33.258	33.258	0.06	0.13		
6	12	5.5	-5.339	5.521	2	-1.617	1.995	5.9	5.579	5.87	50.866	50.866	50.866	0.18	0.38		
6	13	12.1	-11.607	12.101	5.3	-4.28	5.252	13.2	12.371	13.192	114.305	114.305	114.305	0.49	0.97		
7	8	0	0	0	0	0	0	0	0	0	0	0	0	0	0	0	0
7	9	23.6	-23.608	23.608	17.4	-13.822	17.367	29.3	27.356	29.308	237.514	237.514	237.514	0.00	3.55		
9	10	6	-5.914	5.995	4.8	-4.598	4.772	7.7	7.467	7.662	66.525	66.525	66.525	0.08	0.21		
9	14	8.2	-7.718	8.174	4	-3.078	4.047	9.1	8.31	9.121	79.189	79.189	79.189	0.46	0.97		
10	11	-0.9	0.892	0.892	0.2	-0.167	0.175	0.9	0.908	0.908	8.071	8.071	8.071	0.00	0.01		
12	13	0.9	-0.847	0.856	0.4	-0.433	0.442	1	0.951	0.964	8.786	8.786	8.786	0.01	0.01		
13	14	2.7	-2.633	2.696	0.5	-0.393	0.521	2.7	2.662	2.746	25.37	25.37	25.37	0.06	0.13		
TOTAL		496.5	486.736	654.571	669.3	442.466	823.827	1052.9	865.413	1062.225	5596.846	5655.584	5658.287	59.85	226.84		

**5.2: CASE 2: APPLICATION OF TIER-1 COMPENSATION**



**TO THE MODIFIED STANDARD IEEE 14 BUS NETWORK**

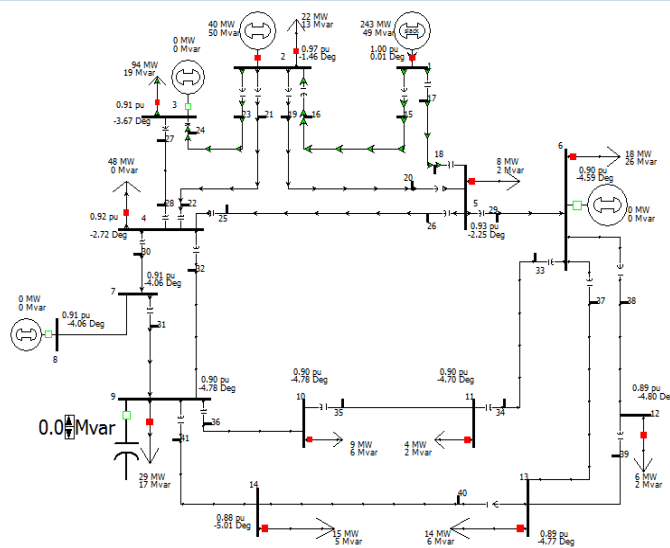

**Figure 8:** Modified standard IEEE 14 bus network with tier-1 compensation

**Table 4A:** Bus records of the Modified standard IEEE 14 bus network with tier-1 compensation.

Bus Records		Nom	Volt	Angle	Load	Load	Gen	Gen	S. Shunts
Number	Name	kV	(kV)	(Deg)	MW	Mvar	MW	Mvar	Mvar
1	1	138	1.0000	138	0.01		243.29	48.73	
2	2	138	0.96558	133.25	-1.46	21.7	12.7	40	50
3	3	138	0.9115	125.787	-3.67	94.2	19.0	0	0
4	4	138	0.92276	127.34	-2.72	47.8	0.00		
5	5	138	0.93304	128.76	-2.25	7.6	1.6		
6	6	138	0.90345	124.676	-4.59	17.8	25.71	0	0
7	7	138	0.90974	125.544	-4.06				
8	8	138	0.90974	125.544	-4.06			0	0
9	9	138	0.90309	124.627	-4.78	29.5	16.6		0
10	10	138	<b>0.89828</b>	123.962	-4.78	9	5.8		
11	11	138	<b>0.89837</b>	123.975	-4.7	3.5	1.8		
12	12	138	<b>0.8919</b>	123.082	-4.8	6.1	1.6		
13	13	138	<b>0.88911</b>	122.697	-4.77	13.5	5.8		
14	14	138	<b>0.88218</b>	121.741	-5.01	14.9	5.0		

**Table 4B:** Line Records of the the Modified standard IEEE 14 bus network with tier-1 compensation.

Line Records		From	To	MW	Mvar	MVA	Max	Max	Max	Amps	Amps	Max	MW	Mvar
From	To	From	To	From	To	From	From	To	From	From	To	From	Loss	Loss
1	2	161.1	156.037	161.15	22.3	-11.831	22.333	162.7	156.49	162.69	677.898	680.23	5.11	10.5
1	5	82.1	-77.844	82.141	37.9	-24.778	37.889	90.5	81.693	90.459	308.555	375.837	4.3	13.11
2	3	78	-74.576	78.019	29.9	-19.244	29.875	83.5	77.019	83.544	354.832	360.119	3.44	10.63
2	4	55.6	-53.473	55.59	17.7	-14.656	17.742	58.4	55.445	58.352	250.09	254.31	2.12	3.09
2	5	40.7	-39.561	40.728	15.4	-14.892	15.393	43.5	42.271	43.54	186.856	191.631	1.17	0.5
3	4	-19.6	19.963	19.963	5.7	-5.885	5.885	20.4	20.812	20.812	93.387	94.764	0.34	-0.21
4	5	-63.7	64.349	64.349	-6.9	8.912	8.912	64.1	64.963	64.963	290.868	290.868	0.65	2.04
4	7	31.4	-31.398	31.398	21.9	-18.51	21.866	38.3	30.448	38.262	167.615	167.615	0.00	3.36
4	9	18	-18.016	18.016	13.3	-10.317	13.256	22.4	20.761	22.267	96.176	96.176	0.00	2.94
5	6	45.5	-45.456	45.456	44.5	-34.435	44.476	63.6	57.027	63.595	264.079	264.079	0.00	10.04
6	11	4.2	-4.222	4.244	1	-0.905	0.951	4.3	4.317	4.349	20.122	20.122	0.02	0.05
6	12	7.2	-7.100	7.191	2.2	-2.038	2.214	7.5	7.393	7.524	34.677	34.677	0.08	0.18
6	13	16.2	-15.985	16.224	6	-5.558	6.03	17.3	16.923	17.309	79.633	79.633	0.24	0.47
7	8	0	0	0	0	0	0	0	0	0	0	0	0	0
7	9	31.4	-31.398	31.398	19.7	-17.98	19.746	37.1	30.182	37.091	167.615	167.615	0.00	1.77
9	10	8.3	-8.277	8.321	6.8	-6.68	6.799	10.7	10.636	10.746	49.539	49.539	0.04	0.12
9	14	11.7	-11.434	11.686	5.4	-4.821	5.356	12.9	12.409	12.855	58.85	58.85	0.25	0.53
10	11	-0.7	0.722	0.722	0.9	-0.879	0.882	1.1	1.138	1.139	5.298	5.298	0.00	0.00
12	13	1.00	-1.003	1.007	0.4	-0.437	0.44	1.1	1.094	1.099	5.15	5.15	0.00	0.00
13	14	3.5	-3.463	3.469	0.2	-0.179	0.233	3.5	3.468	3.497	16.445	16.445	0.03	0.05
TOTAL		511.9	494.215	601.092	244.3	185.113	260.278	742.9	706.48	744.193	3187.685	3212.958	17.79	59.17

The distributed capacitor technology applied on the transmission lines were used in this case to know how much the lines can be freed of their carriage even when the loads were operating. This was verified by placing capacitors on all the lines (interline action) with degree of compensation  $K_s$  allowed to operate by 0.7 or 70% of the original line reactance value. The bus and line results were compared, from which the total active power loss reduced from **59.85 to 17.79MW (70.28% reduction)** while the total reactive power loss reduced from **226.84 to 59.17Mvar (73.92% reduction)**. By this margin, the system's MVA loading was released from **1062.225 to 744.193MVA (29.94% released)**. This is resulted from the reduction in system's current from **5658.287 to 3212.958Amps (43.94% reduction)** with all lines still operating within their normal limits. Bus voltages were also restored appreciably.

Figures 9A-D show the graphical plots of line numbers of the Modified standard IEEE 14 bus network (with tier-1 compensation) against the MW, Mvar, MVA loadings and bus p.u voltages with and without compensation.

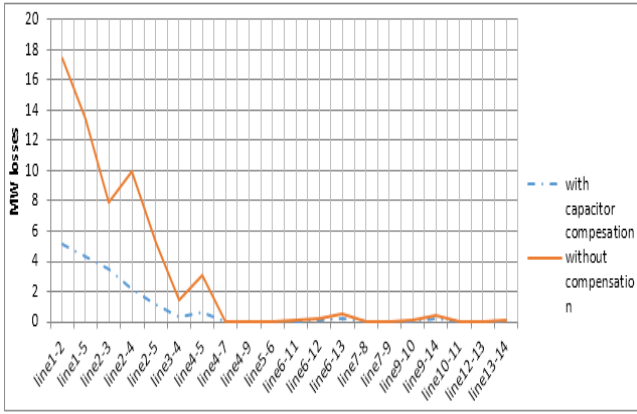

Figure 9A: Line number vs MW losses with and without capacitor compensation on the lines

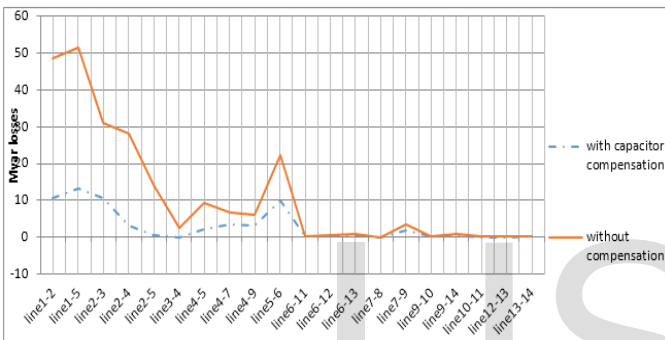

Figure 9B: Line Number vs Mvar Losses with and without capacitor compensation on the lines

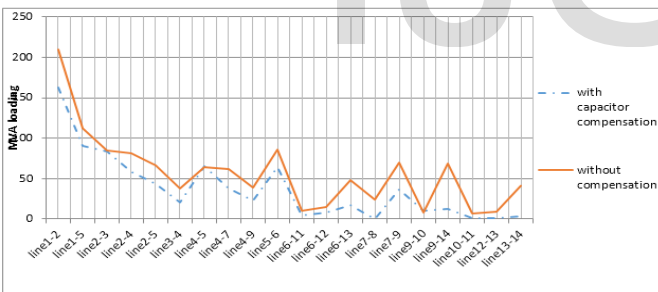

Figure 9C: Line numbers vs MVA Loadings with and without capacitor compensation on the lines

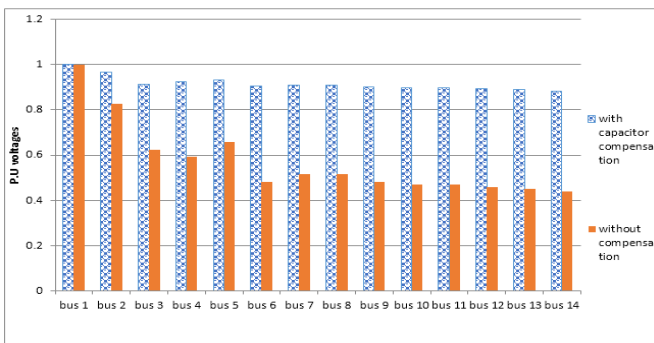

Figure 9D: Bus numbers vs p.u voltages with and without capacitor compensation on the lines

Table 5: Comparison of the modified IEEE 14 bus system voltage performance against operation results of the Tier-1 voltage result as a means of validating the proposed compensation strategy for the bus records.

Bus Records			The modified IEEE 14 bus system (overloaded system)		Use of Tier-1 compensator	
Number	Name	Nom kV	PU Volt	Volt (kV)	PU Volt	Volt (kV)
1	1	138	1	138	1.0000	138
2	2	138	0.82572	113.95	0.96558	133.25
3	3	138	0.62455	86.188	0.9115	125.787
4	4	138	0.59434	82.018	0.92276	127.34
5	5	138	0.6584	90.859	0.93304	128.76
6	6	138	0.48283	66.63	0.90345	124.676
7	7	138	0.51624	71.241	0.90974	125.544
8	8	138	0.51624	71.241	0.90974	125.544
9	9	138	0.48187	66.497	0.90309	124.627
10	10	138	0.4696	64.804	0.89828	123.962
11	11	138	0.47045	64.923	0.89837	123.975
12	12	138	0.45884	63.32	0.8919	123.082
13	13	138	0.45279	62.486	0.88911	122.697
14	14	138	0.43901	60.583	0.88218	121.741

The percentage reduction in MVA loading and savings determines how much the systems corridors have been expanded by the release of the embedded system capacity on which the system can be available for extra loadings.

### 5.3: CONCLUSION

The use of DCC creates more loops in the transmission system by providing more active power routes without having to build new generating stations, new transmission stations or dealing with right-of-way issues. Application of the tier-1 compensation was able to accommodate the added load in the existing 14 bus system by releasing the system up to 29.94% MVA of its overloading which remarkably reduced the system's active losses by 70.28% and reactive losses by 73.92%. Recommendations are made to simultaneously apply also the tier-2 and 3 to the network in other to ensure maximum restoration of the power (up to 100% restoration). This efficient control method can salvage the power system from total collapse and as well serves as a quick way to respond to consumers power satisfaction quest.

### REFERENCES

[1]. H.B. Nagesh and P.S Puttas Wamy, "Power flow Model of Static VAR Compensator and Enhancement of Voltage Stability". IJAET. ISSN: 2231-1963.  
[2]. G.A. Adepoju, O.A. Komolafe, "Power Flow Analysis of the Nigeria Transmission System Incorporating FACTS

- controllers. International Journal of Applied Science and Technology Vol. 1, No 5; Sept 2011.
- [3]. Md. M. Biswas, Kamol K. Das, "Voltage level Improvement by Using Static Var Compensator (SVC), Global Journal of researches in Engineering: J General Engineering. Vol 11 Issue 5, Version 1.0, July 2011. ISSN:0975-5861.
- [4]. Robertas Staniulis "Reactive Power Valuation", Lund University, 2011, CODEN: LUTEDX/(TEIE-5150)/1-42/(2001).
- [5]. K.M. Rogers, and T.J. Overbye, "Some Applications of Distributed AC Transmission System (D-FACTS) devices in power systems". Universidade do Porto. April 05, 2010, IEEE Xplore 978-1-4244-4283-6/08/&25.00 (c) 2008 IEEE.
- [6]. Irinjila Kranti Kiran, Jaya Laximi. A "Shunt Versus Series Compensation in the improvement of power system performance". International Journal of Applied Engineering Research, Dindigul, Vol, No1, 2011. ISSN-0976-4259.
- [7]. Rolf Gruenbum, Jon Rasmussen" Series capacitors for increased power transmission capability of a 500Kv Grid intertie" ABB AB, Vasteras, Sweden, Application Note A02-0222 E, Nov.2010.
- [8]. H.Saadat, "Power system Analysis", McGrawHill Singapore, 1999.
- [9]. Nagrath, D.P Kothari, "Power System Engineering" Tata McGraw Hill publishing company Ltd, New Delhi India, ISBN-0-07-462299-4.
- [10]. Yongan Deng, "Reactive Power compensation of Transmission Lines". Concordia University.
- [11]. I.G. Adebayo, I.A. Adejumbi, O.J. Olajiro, "Power flow Analysis and Voltage Stability Enhancement Using Thyristor Controlled Series Capacitor (TCSC) FACTS Controller" IJEAT, ISSN: 2249-8958, Vol-2, ISSUE-3, Feb 2013.
- [12] Ugwu Peter "Managerial Electrical Maintenance Report". Unpublished technical Report, Electrical Department, General Steel Mill, Asaba, Delta State Nigeria, Jan 2013.